



**Master Pulse Reference/
Isolated Pulse Follower
Expansion Board**

Catalog No. EXB005A01

Installation and Operating Manual

2/03

MN1312

Table of Contents

Section 1	
General Information	1-1
Introduction	1-1
Limited Warranty	1-2
Safety Notice	1-3
Precautions	1-3
Section 2	
Expansion Board Description	2-1
Section 3	
Installation	3-1
Board Installation	3-1
AC Controls	3-2
Single Expansion Board Installation	3-2
Dual Expansion Board Installation	3-4
SCR DC Controls	3-6
Single Expansion Board Installation	3-6
Dual Expansion Board Installation	3-7
Section 4	
Hardware Setup	4-1
Section 5	
Software Setup	5-1
Section 6	
Troubleshooting	6-1



Section 1

General Information

Introduction

The Baldor controls represent the latest technology in microprocessor based motor controls. In addition to the user programmable parameters available in every control, many different expansion boards are available from Baldor to further customize the control to most any application.

Expansion boards are categorized by compatibility into two groups: Group 1 and Group 2, see Table 1-1. A board from either group may be used alone in a control. If two boards are to be used, one board must be from Group 1 and the other from Group 2.

Note: Using two Group 1 or two Group 2 boards in the same control is not allowed.

Table 1-1 Group 1 and Group 2 Board Categories

Group 1 Board Name	Catalog No.	Manual No.
Isolated Input	EXB003A0X	MN1314
Master Pulse Reference/ Isolated Pulse Follower	EXB005A0X	MN1312
DC Tachometer Interface	EXB006A0X	MN1311
Isolated Encoder	EXB008A0X	MN1317
Resolver to Digital Interface	EXB009A0X	MN1313
Group 2 Board Name		
RS-232 Serial	EXB001A0X	MN1310
RS-422/RS-485 Serial	EXB002A0X	MN1310
RS-232/485 Serial	EXB012A0X	MN1310
Four Output Relays/3-15 PSI Pneumatic	EXB004A0X	MN1315
High Resolution Analog I/O	EXB007A0X	MN1316
2 Isolated Analog Output/ 3 Relay Output	EXB010A0X	MN1319
Device Net	EXB013A0X	MN1320
Modbus Plus	EXB015A0X	MN1322
Profibus DP	EXB014A0X	MN1323

Limited Warranty

For a period of two (2) years from the date of original purchase, BALDOR will repair or replace without charge controls and accessories which our examination proves to be defective in material or workmanship. This warranty is valid if the unit has not been tampered with by unauthorized persons, misused, abused, or improperly installed and has been used in accordance with the instructions and/or ratings supplied. This warranty is in lieu of any other warranty or guarantee expressed or implied. BALDOR shall not be held responsible for any expense (including installation and removal), inconvenience, or consequential damage, including injury to any person or property caused by items of our manufacture or sale. (Some states do not allow exclusion or limitation of incidental or consequential damages, so the above exclusion may not apply.) In any event, BALDOR's total liability, under all circumstances, shall not exceed the full purchase price of the control. Claims for purchase price refunds, repairs, or replacements must be referred to BALDOR with all pertinent data as to the defect, the date purchased, the task performed by the control, and the problem encountered. No liability is assumed for expendable items such as fuses.


Goods may be returned only with written notification including a BALDOR Return Authorization Number and any return shipments must be prepaid.


Safety Notice

This equipment contains voltages that may be as great as 1000 volts! Electrical shock can cause serious or fatal injury. Only qualified personnel should attempt the start-up procedure or troubleshoot this equipment.

This equipment may be connected to other machines that have rotating parts or parts that are driven by this equipment. Improper use can cause serious or fatal injury. Only qualified personnel should attempt the start-up procedure or troubleshoot this equipment.

PRECAUTIONS

 **WARNING:** Do not touch any circuit board, power device or electrical connection before you first ensure that power has been disconnected and there is no high voltage present from this equipment or other equipment to which it is connected. Electrical shock can cause serious or fatal injury. Only qualified personnel should attempt the start-up procedure or troubleshoot this equipment.

 **WARNING:** Be sure that you are completely familiar with the safe operation of this equipment. This equipment may be connected to other machines that have rotating parts or parts that are controlled by this equipment. Improper use can cause serious or fatal injury. Only qualified personnel should attempt the start-up procedure or troubleshoot this equipment.

-
- ⚠ WARNING:** Be sure the system is properly grounded before applying power. Do not apply AC power before you ensure that all grounding instructions have been followed. Electrical shock can cause serious or fatal injury.
- ⚠ WARNING:** Do not remove cover for at least five (5) minutes after AC power is disconnected to allow capacitors to discharge. Dangerous voltages are present inside the equipment. Electrical shock can cause serious or fatal injury.
- ⚠ WARNING:** Improper operation of control may cause violent motion of the motor shaft and driven equipment. Be certain that unexpected motor shaft movement will not cause injury to personnel or damage to equipment. Peak torque of several times the rated motor torque can occur during control failure.
- ⚠ WARNING:** Motor circuit may have high voltage present whenever AC power is applied, even when motor is not rotating. Electrical shock can cause serious or fatal injury.
- ⚠ Caution:** To prevent equipment damage, be certain that the electrical service is not capable of delivering more than the maximum line short circuit current amperes listed in the appropriate control manual, 230 VAC, 460 VAC or 575 VAC maximum per control rating.

Section 2

Expansion Board Description

Introduction

Master Pulse Reference/Isolated Pulse Follower (MPR/F)
Expansion Board Catalog No. EXB005A01

Features:

- Group 1
- Master/Follower Operation
- Velocity Ratioing
- Position Following (with EXB009A01 resolver feedback)

Velocity ratioing is speed matching of two or more drives. Master follower ratios are set using integers within the range of 65535:1 to 1:65535. Fractional ratios can be set using integers, e.g. a 2.5:1 ratio is set at 5:2.

Position following or electronic gearing is pulse to pulse following of two or more drives. Master follower ratios are set using integers within the range of 65535:1 to 1:65535. Fractional ratios can be set using integers, e.g. a 2.5:1 ratio is set at 5:2. Position following is only possible when the motor mounted feedback devices are resolvers and a resolver to digital interface expansion board No. EXB009A01 is installed in each control.

Note: If the master is to run faster than the follower, ratios of master to follower may be as high as 65535:1.

Note: If the follower is to run faster than the master, the following ratio limits apply:
Series 15H/21H Inverters - 1:MAX Motor RPM
Series 18H/22H Vectors - 1:20
Series 19H/20H SCR DC w/armature or encoder Feedback - 1:20
Series 23H Servos - 1:20

The MPR/F board characteristics are defined in Table 2-1.

Table 2-1 Characteristics

Input Voltage Level	5 - 15 VDC
Retransmit Voltage Level	5 VDC
Input Signal Types (Independent of Output)	Quadrature or Speed/Direction
Output Signal Types (Independent of Input)	Quadrature or Speed/Direction
Input/Output Ratio (adjusted within the control)	Adjustable ratio from 65535:1 to 1:65535 *
Operating Modes	Master or Follower
Connection method	Parallel or Cascade

* Subject to limitations on page 2-1.

Configurations

The MPR/F board can be installed to configure a Baldor Series H control as either a master or follower drive in a process. The configurations differ by control type and configuration. The available configurations are shown in Table 2-4.

Table 2-2 Velocity, Position or Speed & Direction Selection

Control Type	EXB Configuration	Velocity Following		Position ^① Following		Speed & Direction	
		M	F	M	F	M	F
15H Inverter	Parallel	X	X			X	X
18H Vector	Cascade or Parallel		X		X		X
19H SCR DC w/Encoder FB	Cascade or Parallel		X		X		X
19H SCR DC w/Armature or Tach FB	Parallel	X	X			X	X
20H SCR DC w/Encoder FB	Cascade or Parallel		X		X		X
20H SCR DC w/Armature or Tach FB	Parallel	X	X			X	X
21H Inverter	Parallel	X	X			X	X
22H Vector w/Encoder FB	Cascade or Parallel		X		X		X
23H AC Servo	Cascade or Parallel		X		X*		X

M=Master; F=Follower; FB=Feedback;

* Requires Resolver FB (instead of encoder) and Resolver to Digital Interface.

- ① For Position following, set the value of the Position Gain parameter to a value greater than 0. For Velocity following, set the value of the Position Gain parameter to 0.

Note: Position Gain parameter is found in the Level 1 Vector Control block, Level 1 DC Control block, or Level 1 Brushless Control block.

Definitions

Parallel Configuration

In a parallel configuration all follower controls receive the master pulse train. All Followers are ratioed to the master pulse train. The master pulse train can originate from the first motor control in the process or from an encoder located ahead of the first control.

Cascade Configuration

In a Cascade configuration all follower controls receive the pulse train from the control directly ahead of it in the process. If the master is a control that does not have a buffered encoder output at its control terminal strip, an MPR/F expansion board must be installed in the master and all follower controls. Otherwise, only the followers require MPR/F expansion boards be installed.

Master

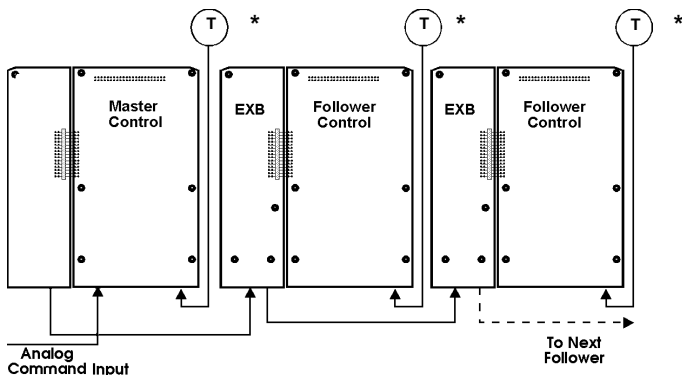
The master is the first pulse generator in the process. This can be the first control in the process or from an encoder located ahead of the first control.

Follower

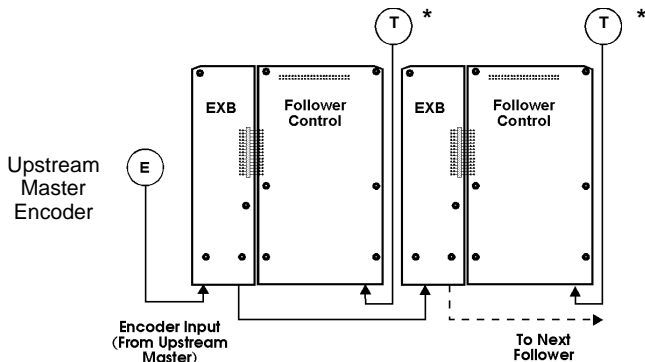
A follower is a control in the process that is ratioed to the master pulse train. In a parallel configuration all followers are ratioed to a single master. In a Cascade configuration followers are ratioed to the pulse train of the control directly ahead of it in the process.

Figures 2-1 through 2-8 show the Parallel and Cascade configurations of master and follower controls.

**Figure 2-1 Parallel Master and Follower
(Series 15H/21H Inverters
Series 19H/20H w/Armature or Tach FB)**

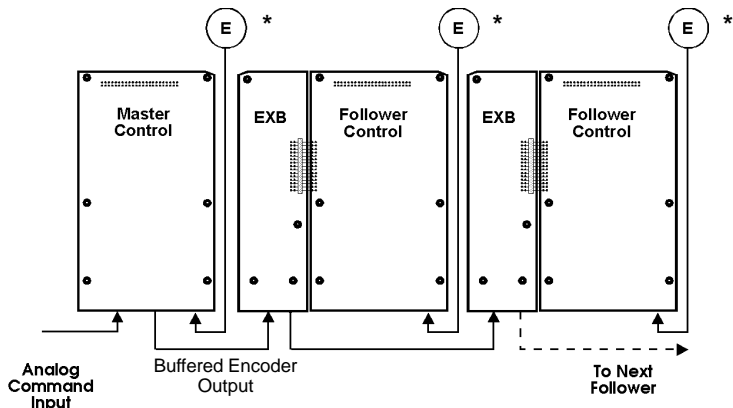


**Figure 2-2 Parallel Following Upstream Encoder
(Series 15H/21H Inverters
Series 19H/20H w/Armature or Tach FB)**

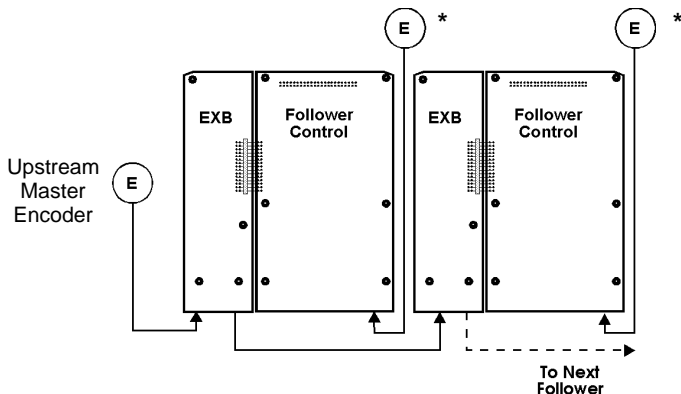


***Note:** Tach feedback for 19H/20H SCR DC controls.
Tach not present when using armature feedback.
Tach not present for 15H/21H Inverters.

**Figure 2-3 Parallel Master and Follower
(Series 18H/19H/20H/22H/23H**)**



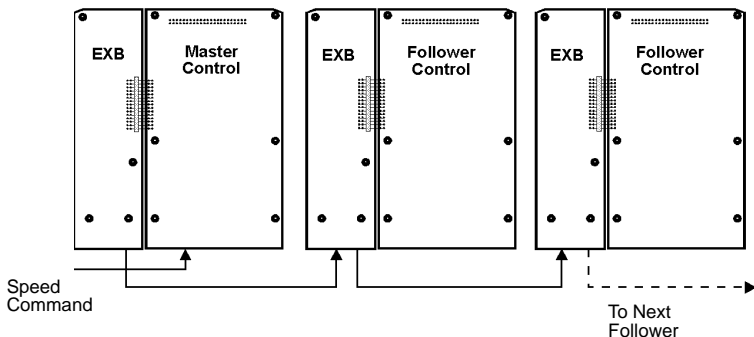
**Figure 2-4 Parallel Following Upstream Encoder
(Series 18H/19H/20H/22H/23H**)**



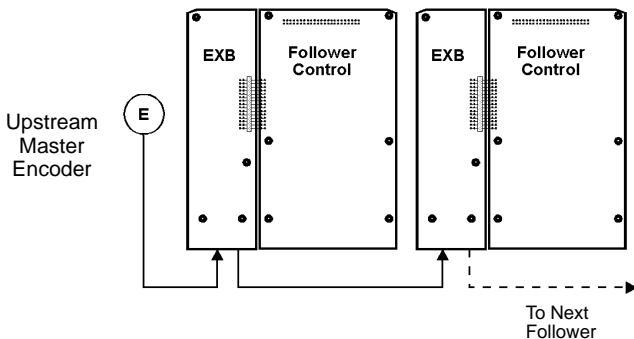
*Note: Encoder feedback.

**Note: 23H uses Resolver feedback.

**Figure 2-5 Cascade Master and Follower*
(Series 15H/21H)**

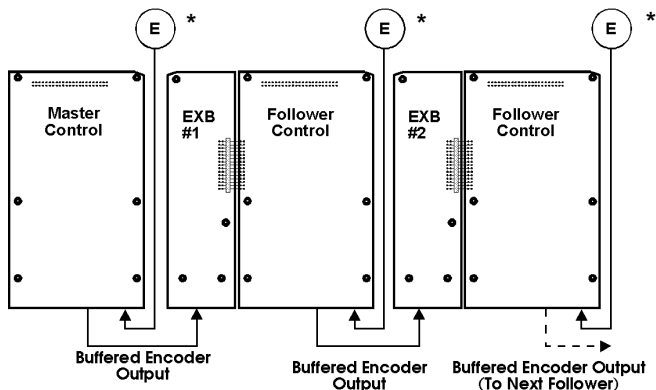


**Figure 2-6 Cascade Following Upstream Encoder*
(Series 15H/21H)**

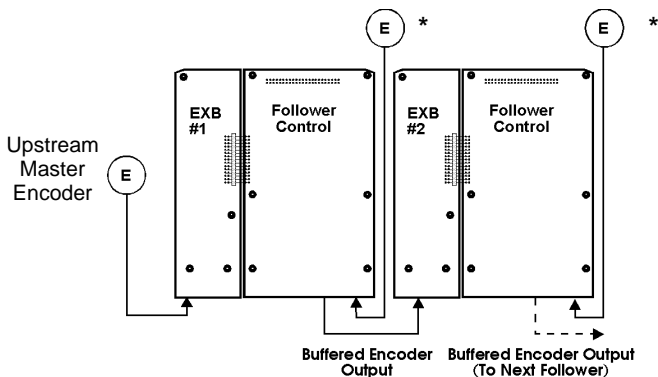


*Note: Cascade operation when the Encoder Counts parameter of each follower is different than master and Master/Follower ratio is set between each control.

**Figure 2-7 Cascade Master and Follower
(Series 18H/19H/20H/22H/23H**)**



**Figure 2-8 Cascade Following Upstream Encoder
(Series 18H/19H/20H/22H/23H**)**



*Note: Encoder feedback.

**Note: 23H uses Resolver feedback.

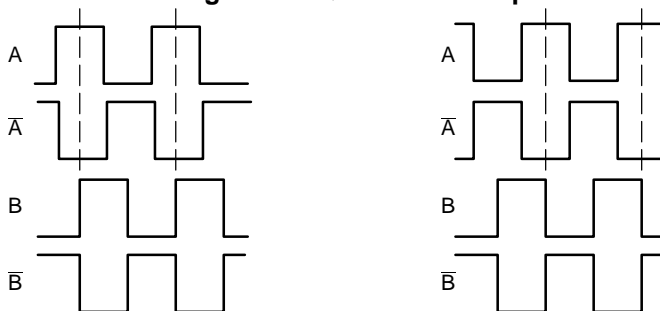
Operating Modes

Two operating modes are selectable on the MPR/F board; Quadrature and Speed/Direction. The master pulse train can be a 5 - 15 VDC signal level and will be retransmitted by the MPR/F board as a 5 VDC signal level.

Quadrature

The factory setting uses a two channel quadrature pulse train (identical to a standard encoder pulse train). The waveform of the quadrature outputs is shown in Figure 2-9. The channels are identified as A, \bar{A} , B and \bar{B} . Where A and B channels are in quadrature and \bar{A} is a complement of A, and \bar{B} is a complement of B.

Figure 2-9 Quadrature Output



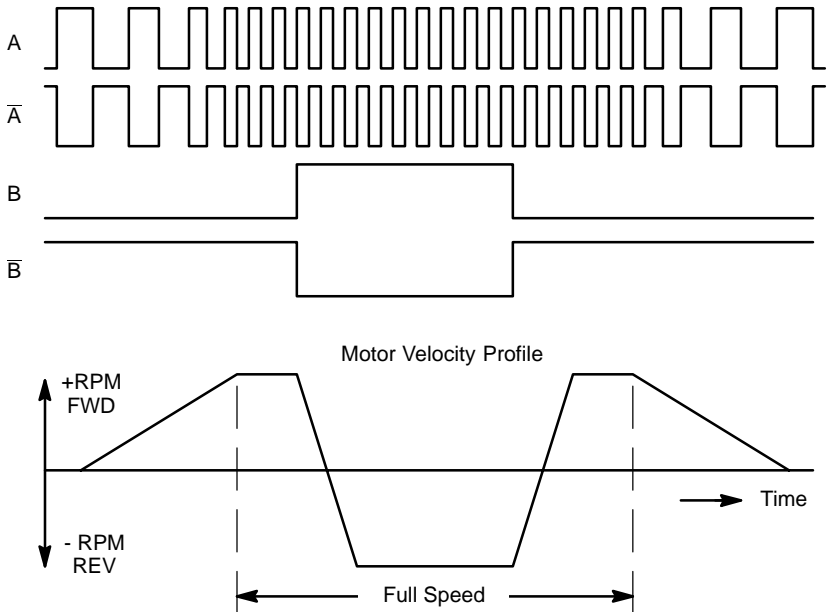
Quadrature: A Leading B

Quadrature: B Leading A

Speed/Direction

In Speed/Direction mode, the frequency of the A channel controls motor speed and the state of the B Channel controls rotational direction. The waveform is shown in Figure 2-10.

Figure 2-10 Speed/Direction Output



Tables 2-3 and 2-4 define the available operating modes by control type for both master and follower configurations.

Table 2-3 Master Mode Configurations

Control Type	Operating Mode							
	Key-pad	Std Run	15 Spd	3 Wire Fan/Pump	2 Wire Fan/Pump	Bi-polar	Process	Serial
15H Master	1	1	1	1	1		1	1
18H Master	2	2	2			2	2	2
19H Arm/Tach FB Master	1	1	1				1	1
19H Encoder FB Master	3	3	3				3	3
20H Arm/Tach FB Master	1	1	1			1	1	1
20H Encoder FB Master	3	3	3			3	3	3
21H Master	1	1	1	1	1		1	1
22H Master	2	2	2			2	2	2

1 Requires EXB005A01.

2 Uses control Buffered Encoder output only. (EXB005A01 not allowed).


3 Use either control Buffered Encoder output or EXB005A01.

 Not Available.

Table 2-4 Follower Mode Configurations

Control Type	Operating Mode							
	Key-pad	Std Run	15 Spd	3 Wire Fan/Pump	2 Wire Fan/Pump	Bi-polar	Process	Serial
15H Follower		1		1	1		1	
18H Follower		1				1	1	
19H Arm/Tach FB Follower		1				1	1	
19H Encoder FB Follower		1				1	1	
20H Arm/Tach FB Follower		1				1	1	
20H Encoder FB Follower		1				1	1	
21H Follower		1		1	1		1	
22H Follower		1				1	1	
23H Follower		1				1	1	

1 Requires EXB005A01.


 Not Available.

Section 3


Installation

Board Installation

This section describes the Expansion Board installation procedure.

 **Caution:** Before you proceed, be sure to read and become familiar with the safety precautions at the beginning of this manual. Do not proceed if you are unsure of the safety precautions described. If you have any questions, contact BALDOR before you proceed.

1. Remove the expansion board from the shipping container.
2. Remove all packing material from the board.

 **Caution:** Be sure all packing materials are removed from the board. Conductive foam may be present on the connectors to prevent static build up during shipping. This can prevent proper circuit operation.

If you are installing only one board, refer to the “Single Expansion Board Installation” procedure. If you are installing two expansion boards (or a second board) refer to the “Dual Expansion Board Installation” procedure.

AC Controls

(For all 15H Inverter, 21H Line Regen Inverter, 18H Vector, 22H Line Regen Vector and 23H Servo).

Single Expansion Board Installation

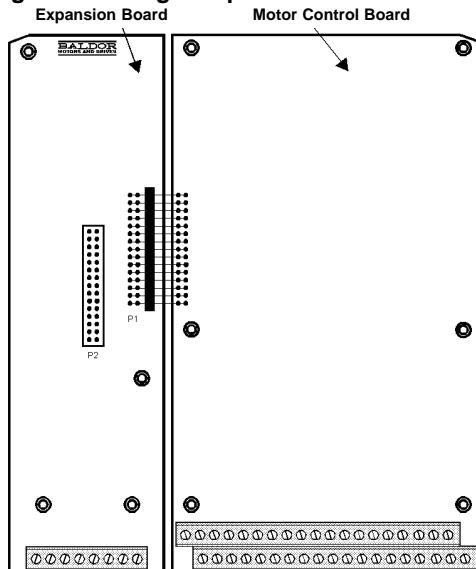
Procedure:

1. Be sure drive operation is terminated and secured.
2. Remove all power sources from the control.
3. Wait at least 5 minutes for internal capacitors to discharge.
4. Remove the four (4) Phillips head screws ($1/4$ turn) that secure the control cover. (For A & B size, remove four screws that secure the cover. On floor mounted G size enclosures, open the enclosure door).
5. Remove the control cover.
6. Slide the expansion board male connector into the female connector of the control board. See Figure 3-1.
7. Securely mount the expansion board to the sheet metal mounting plate using the #6 screws provided in the installation hardware. See Figure 3-2.
8. The mechanical installation of the expansion board is now complete. Refer to Section 4 of this manual and configure the jumpers as desired. Also complete the wiring before you proceed to step 9.
9. When complete, install the control cover using the four (4) Phillips head screws ($1/4$ turn). (For A & B size, install four screws that secure the cover. On floor mounted G size enclosures, close the enclosure door).
10. Restore all power sources to the control.
11. Restore drive operation.

AC Controls

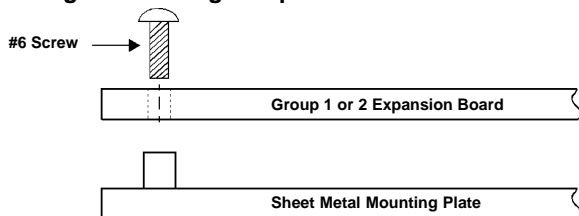
Single Expansion Board Installation (Continued)

Figure 3-1 Single Expansion Board Installation



Terminal tightening torque is 7 lb-in (0.8 Nm) maximum.

Figure 3-2 Single Expansion Board Installation



AC Controls (Continued)

Dual Expansion Board Installation

Procedure:

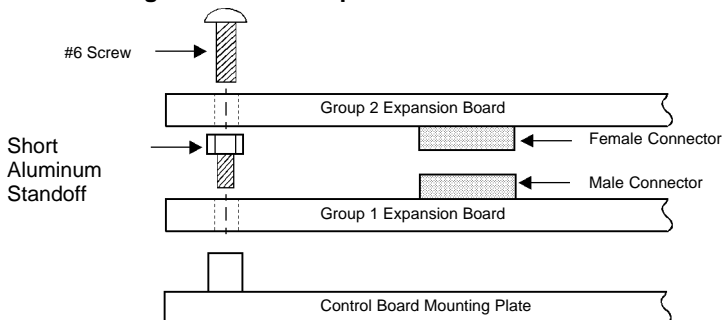
1. Be sure drive operation is terminated and secured.
2. Remove all power sources from the control.
3. Wait at least 5 minutes for internal capacitors to discharge.
4. Remove the four (4) Phillips head screws ($\frac{1}{4}$ turn) that secure the control cover. (For A & B size, remove four screws that secure the cover. On floor mounted G size enclosures, open the enclosure door).
5. Remove the control cover.
6. Slide the Group 1 expansion board male connector into the female connector of the control board. See Figure 3-1.
7. Securely mount the Group 1 expansion board to the sheet metal mounting plate using the short standoffs provided in the installation hardware. See Figure 3-3.
8. The mechanical installation of the expansion board is now complete. Refer to the manual for the Group 1 board and configure the jumpers as desired. Also complete the wiring before you proceed to step 9.
9. Install the Group 2 board on top of the previously installed Group 1 board by plugging the female connector onto the male connector of the Group 1 board as shown in Figure 3-3.
10. Secure this Group 2 board to the Group 1 board using the #6 screws provided. See Figure 3-3.
11. The mechanical installation of the expansion board is now complete. Refer to the manual for the Group 2 board and configure any jumpers and switches as desired. Also complete the wiring for this board before you install or close the cover.

AC Controls

Dual Expansion Board Installation (Continued)

- When complete, install the control cover using the four (4) Phillips head screws ($\frac{1}{4}$ turn). (For A & B size, install four screws that secure the cover. On floor mounted G size enclosures, close the enclosure door).
- Restore all power sources to the control.
- Restore drive operation.

Figure 3-3 Dual Expansion Board Installation



SCR DC Controls

(For 19H and 20H SCR DC Controls).

Single Expansion Board Installation

Procedure:

1. Be sure drive operation is terminated and secured.
2. Remove all power sources from the control.
3. Wait at least 5 minutes for internal capacitors to discharge.
4. Slide the expansion board male connector into the female connector of the control board. See Figure 3-1.
5. Securely mount the expansion board to the sheet metal mounting plate using the #6 screws provided in the installation hardware. See Figure 3-2.
6. The mechanical installation of the expansion board is now complete. Refer to the Group 1 manual and configure the jumpers as desired. Also complete the wiring before you proceed to step 7.
7. Restore all power sources to the control.
8. Restore drive operation.

SCR DC Controls (Continued)

Dual Expansion Board Installation

Procedure:

1. Be sure drive operation is terminated and secured.
2. Remove all power sources from the control.
3. Wait at least 5 minutes for internal capacitors to discharge.
4. Slide the Group 1 board male connector into the female connector of the control board. See Figure 3-1.
5. Securely mount the Group 1 expansion board to the sheet metal mounting plate using the short standoffs provided in the installation hardware. See Figure 3-3.
6. The mechanical installation of the expansion board is now complete. Refer to the Group 1 manual and configure the jumpers as desired. Also complete the wiring before you proceed to step 7.
7. Install the Group 2 board on top of the previously installed Group 1 board by plugging the female connector onto the male connector of the Group 1 board as shown in Figure 3-3.
8. Secure this Group 2 board to the Group 1 board using the #6 screws provided. See Figure 3-3.
9. The mechanical installation of the expansion board is now complete. Refer to the manual for the Group 2 board and configure any jumpers and switches as desired. Also complete the wiring for this board before you proceed to step 10.
10. Restore all power sources to the control.
11. Restore drive operation.



Section 4

Hardware Setup

DIP Switch Settings

Hardware setup consists of setting the DIP switches for the operation desired. The Master Pulse Reference/Isolated Pulse Follower board is a programmable digital pulse interface to the Motor Control Board.

Figure 4-1 shows the location of the DIP switches on the MPR/F board. Figure 4-2 provides a close up view of the DIP switches. The position of switches 1, 2, and 3 determines how the board will function. Switch 4 is not used and may be left in either position. To select a desired mode, press the appropriate switch in the direction of the function name (names are labeled on the circuit board). As shown in Figure 4-2, the DIP switches are set for Follower, Quadrature In and Quadrature Out. Figure 4-3 shows four possible combinations of the DIP switch settings (Master, Follower, Quadrature and Speed and Direction). Set the switches for the operation desired.

Note: Switch 4 is not used and may be left in either position.

Figure 4-1 DIP Switch and Terminal Locations

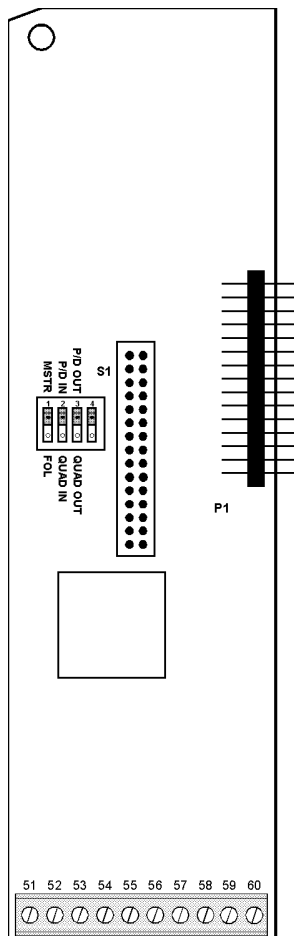
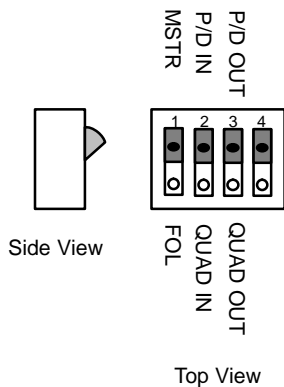
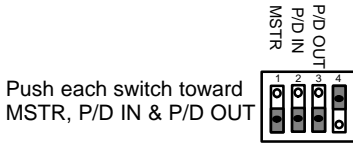


Figure 4-2 DIP Switch Settings

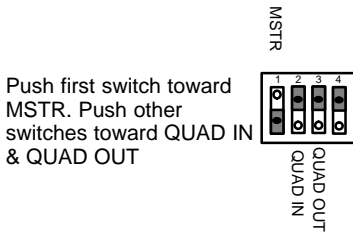


Terminal tightening torque is 7 lb-in (0.8 Nm) maximum.

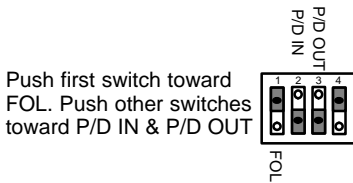
Figure 4-3 Switch Settings



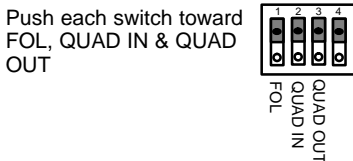
**Master Speed and Direction
Pulse Reference Mode**



**Master Quadrature
Pulse Reference Mode**



**Speed and Direction
Pulse Follower Mode**



**Quadrature
Pulse Follower Mode**

Note: Switch 4 is not used and may be left in either position.

Wiring the MPR/F Board

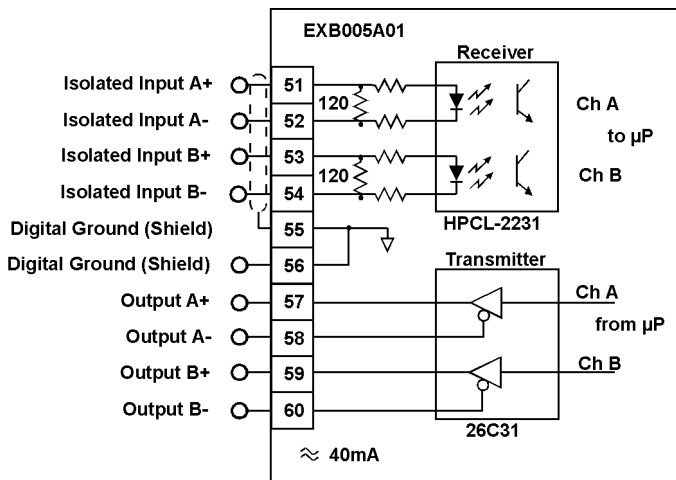
All connections are made between the master encoder or the master control terminal strip and the terminal strip at the edge of the MPR/F. Use two #22 AWG (.324mm²) (minimum) twisted pair wires with an overall insulated shield. Limit the distance between master and follower control(s) to 150 feet (45m) maximum. Connect the shields only to digital ground which is terminal 55 of the MPR/F board. Terminal tightening torque is 7 lb-in (0.8 Nm) maximum.

The quadrature inputs of the MPR/F board are optically isolated from the motor control's main control board. These inputs are terminals 51, 52 53 and 54 of the MPR/F board. The quadrature output and digital grounds of the MPR/F board (terminals 56, 57, 58, 59 and 60) are referenced to the control board digital ground.

Various types of encoders may be used, such as dual channel line driver output encoders, dual channel open collector output encoders, single channel line driver output encoders, single channel open collector output encoders. Single channel encoders may be used with pulse and direction only (not quadrature). Wiring diagrams of these types encoder types are shown in Figures 4-4 through 4-8.

Use proper grounding techniques when connecting several controls or devices to the MPR/F board.

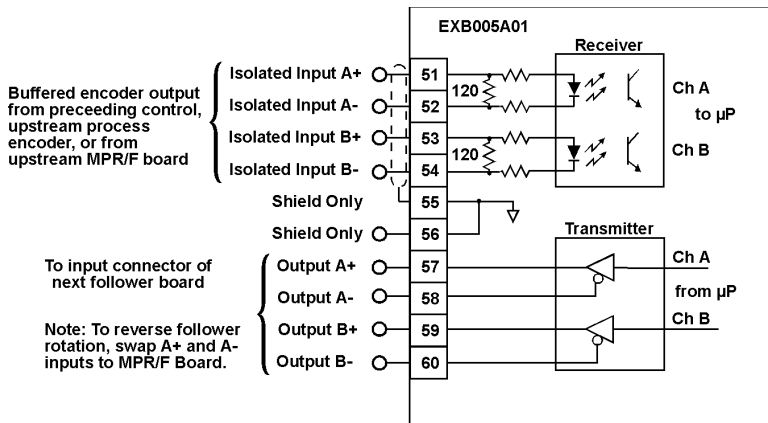
Figure 4-4 General Connection Diagram MPR/F Board



Terminal tightening torque is 7 lb-in (0.8 Nm) maximum.

⚠ Caution: Tie shield at one end only. For example, connect the shields to pin 55 of each MPR/F board and insulate or tape off the ungrounded end of shields to prevent contact with other conductors or ground.

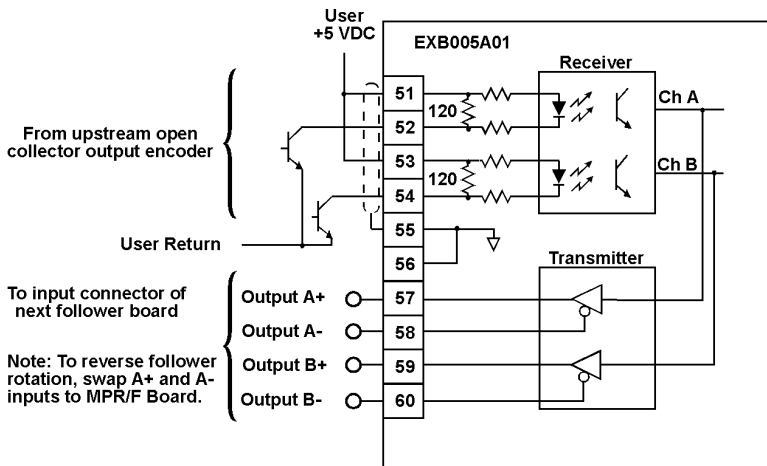
Figure 4-5 Dual Channel Line Driver Encoder



Terminal tightening torque is 7 lb-in (0.8 Nm) maximum.

⚠ Caution: Tie shield at one end only. For example, connect the shields to pin 55 of each MPR/F board and insulate or tape off the ungrounded end of shields to prevent contact with other conductors or ground.

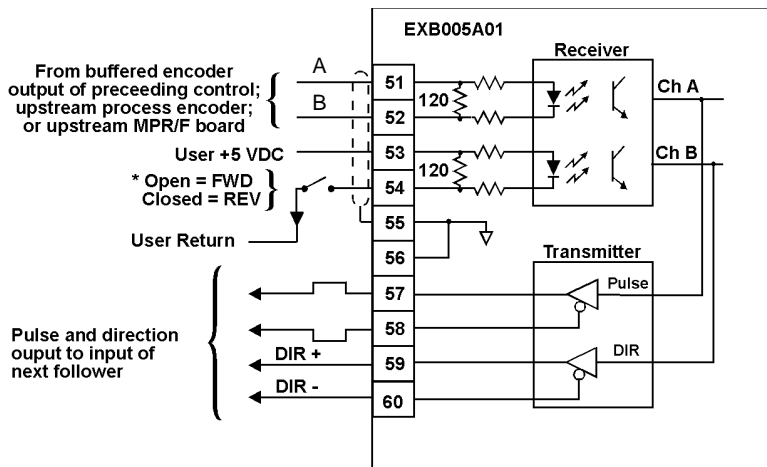
Figure 4-6 Dual Channel Open Collector Encoder



Terminal tightening torque is 7 lb-in (0.8 Nm) maximum.

⚠ Caution: Tie shield at one end only. For example, connect the shields to pin 55 of each MPR/F board and insulate or tape off the ungrounded end of shields to prevent contact with other conductors or ground.

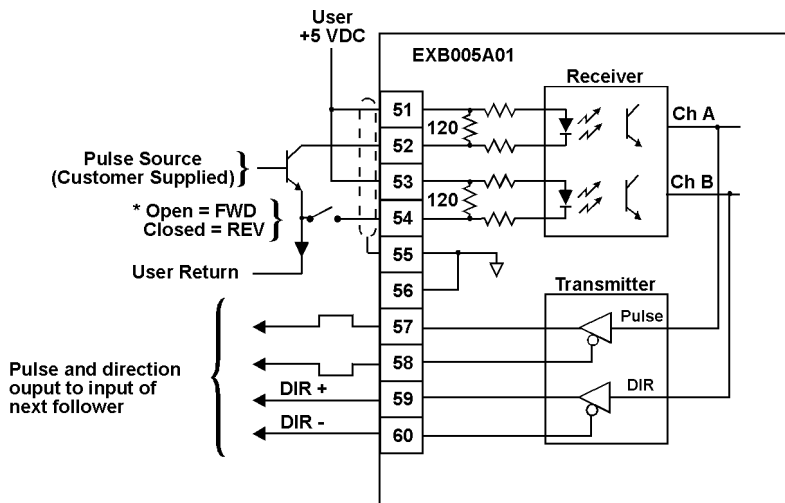
Figure 4-7 Single Channel Line Driver Encoder



Terminal tightening torque is 7 lb-in (0.8 Nm) maximum.

⚠ Caution: Tie shield at one end only. For example, connect the shields to pin 55 of each MPR/F board and insulate or tape off the ungrounded end of shields to prevent contact with other conductors or ground.

Figure 4-8 Single Channel Open Collector Encoder



Terminal tightening torque is 7 lb-in (0.8 Nm) maximum.

⚠ Caution: Tie shield at one end only. For example, connect the shields to pin 55 of each MPR/F board and insulate or tape off the ungrounded end of shields to prevent contact with other conductors or ground.



Section 5

Software Setup

Overview

Before attempting to operate drives in a Master/Follower configuration, the control must first successfully operate its' motor without the MPR/F board installed. After successful operation of the motor and control, the MPR/F board may be installed and the Master-Follower operation can be programmed.

Programming the control for Master-Follower operation is accomplished using the keypad of the control. General programming steps are defined in the appropriate control manual.

Master Quadrature Pulse Reference Mode for Series 15H and 21H Inverters

Be sure an MPR/F expansion board is installed in the control which will be the Master. Check that the main control board terminal strip is wired for the controls' operating mode and the MPR/F expansion board output terminals are connected to the input terminals of an MPR/F expansion board installed in a Follower control.

Note: Position following is not possible with Series 15H and 21H inverters.

Use the keypad to set these Level 1 parameters:

<u>Block</u>	<u>Parameter</u>	<u>Setting</u>
INPUT	OPERATING MODE	See Table 2-3
INPUT	COMMAND SELECT	As desired for operating mode selected
ACCEL/DECEL RATE	ACCEL 1	As desired
ACCEL/DECEL RATE	DECEL 1	As desired
ACCEL/DECEL RATE	S-CURVE 1	As desired

The Master control is now ready for operation. The Follower control must now be programmed for the Quadrature Pulse Follower Mode for the appropriate control, ie. 15H, 18H, etc. Proceed to that section of this manual.

Quadrature Pulse Follower Mode for Series 15H and 21H Inverters

Be sure an MPR/F expansion board is installed in the Follower control and the input terminals of the expansion board are wired to the quadrature output of a Master control or encoder located ahead of this Follower control in the process. Check that the main control board terminal strip is wired for the controls' operating mode.

Note: Position following is not possible with Series 15H and 21H inverters.

Use the keypad to set these Level 1 parameters:

<u>Block</u>	<u>Parameter</u>	<u>Setting</u>
INPUT	OPERATING MODE	See Table 2-4
INPUT	COMMAND SELECT	EXB PULSE FOL
ACCEL/DECEL RATE	ACCEL 1	Set to 0 to follow Master Profile
ACCEL/DECEL RATE	DECEL 1	Set to 0 to follow Master Profile
ACCEL/DECEL RATE	S-CURVE 1	Set to 0 to follow Master Profile

Use the keypad to set these Level 2 parameters:

<u>Block</u>	<u>Parameter</u>	<u>Setting</u>
PROCESS CONTROL	ENCODER COUNTS	Encoder counts of Master pulse train

Continued on next page

Quadrature Pulse Follower Mode for Series 15H and 21H Inverters Continued

For all operating modes except Serial:

<u>Block</u>	<u>Parameter</u>	<u>Setting</u>
PROCESS CONTROL	FOLLOW I:O RATIO	Desired integer ratio between Master and Follower quadrature encoder counts

For Serial Operating Mode Only:

<u>Block</u>	<u>Parameter</u>	<u>Setting</u>
PROCESS CONTROL	FOLLOW I:O RATIO	Master of encoder counts ratio
PROCESS CONTROL	FOLLOW I:O OUT	Follower of encoder counts ratio

The Follower drive is now ready to follow the velocity of the Master. Be sure to “Enable” both the Master and Follower controls to allow Master/Follower operation.

Master Speed and Direction Pulse Reference Mode for Series 15H and 21H Inverters

Be sure an MPR/F expansion board is installed in the control which will be the Master. Check that the main control board terminal strip is wired for the controls' operating mode and the MPR/F expansion board output terminals are connected to the input terminals of an MPR/F expansion board installed in a Follower control.

Use the keypad to set these Level 1 parameters:

<u>Block</u>	<u>Parameter</u>	<u>Setting</u>
INPUT	OPERATING MODE	See Table 2-3
INPUT	COMMAND SELECT	As desired for operating mode selected
ACCEL/DECEL RATE	ACCEL 1	As desired
ACCEL/DECEL RATE	DECEL 1	As desired
ACCEL/DECEL RATE	S-CURVE 1	As desired

The Master control is now ready for operation. The Follower control must now be programmed for Speed and Direction Follower mode operation. Proceed to the appropriate section of this manual to program Speed and Direction Follower Mode for the appropriate control, ie. 15H, 18H, etc.

Speed and Direction Pulse Follower Mode for Series 15H and 21H Inverters

Be sure an MPR/F expansion board is installed in the Follower control and the input terminals of the expansion board are wired to the speed and direction output of a Master control or encoder located ahead of the Follower control in the process. Check that the main control board terminal strip is wired for the controls' operating mode.

Note: Position following is not possible with 15H and 21H Inverter controls.

Use the keypad to set these Level 1 parameters:

<u>Block</u>	<u>Parameter</u>	<u>Setting</u>
INPUT	OPERATING MODE	See Table 2-4
INPUT	COMMAND SELECT	EXB PULSE FOL
ACCEL/DECEL RATE	ACCEL 1	Set to follow Master Profile
ACCEL/DECEL RATE	DECEL 1	Set to follow Master Profile
ACCEL/DECEL RATE	S-CURVE 1	Set to follow Master Profile

Use the keypad to set these Level 2 parameters:

<u>Block</u>	<u>Parameter</u>	<u>Setting</u>
PROCESS CONTROL	ENCODER COUNTS	Encoder counts of Master pulse train

Continued on next page

Speed and Direction Pulse Follower Mode for Series 15H and 21H Inverters Continued

For all operating modes except Serial:

<u>Block</u>	<u>Parameter</u>	<u>Setting</u>
PROCESS CONTROL	FOLLOW I:O RATIO	Desired integer ratio between Master and Follower speed and direction

For Serial Operating Mode only:

<u>Block</u>	<u>Parameter</u>	<u>Setting</u>
PROCESS CONTROL	FOLLOW I:O RATIO	Master of encoder counts ratio
PROCESS CONTROL	FOLLOW I:O OUT	Follower of encoder counts ratio

The Follower drive is now ready to follow the velocity of the Master. Be sure to “Enable” both the Master and Follower controls to allow Master/Follower operation.

Master Quadrature Pulse Reference Mode for Series 19H/20H SCR DC Drives with Armature or Analog Tach Feedback

Be sure an MPR/F expansion board is installed in the control. Check that the main control board terminal strip is wired for either the controls' operating mode and the MPR/F expansion board output terminals are connected to the input terminals of an MPR/F expansion board installed in a Follower control.

Note: Position following is not possible with Armature or Analog Tach Feedback Series 19H or 20H SCR DC drives.

Use the keypad to set these Level 1 parameters:

<u>Block</u>	<u>Parameter</u>	<u>Setting</u>
INPUT	OPERATING MODE	See Table 2-3
INPUT	COMMAND SELECT	As desired for operating mode selected
ACCEL/DECEL RATE	ACCEL 1	As desired
ACCEL/DECEL RATE	DECEL 1	As desired
ACCEL/DECEL RATE	S-CURVE 1	As desired

The Master drive is now ready for operation. The Follower control must now be programmed for Follower mode operation. Proceed to the appropriate section of this manual to program Pulse Follower operation for the appropriate control, ie. 15H, 18H, etc.

Quadrature Pulse Follower Mode for Series 19H/20H SCR DC Drives with Armature or Analog Tach Feedback

Be sure an MPR/F expansion board is installed in the Follower control. Check that the input terminals of the expansion board are wired to the quadrature output of a Master control or an encoder located ahead of this Follower in the process. Check that the main control board terminal strip is wired for the controls' operating mode.

Note: Position following (electronic gearing) is not possible using armature or analog tach feedback Series 19H or 20H SCR DC drives.

Use the keypad to set these Level 1 parameters:

<u>Block</u>	<u>Parameter</u>	<u>Setting</u>
INPUT	OPERATING MODE	See Table 2-4
INPUT	COMMAND SELECT	EXB PULSE FOL
ACCEL/DECEL RATE	ACCEL 1	Set to 0 to follow Master Profile
ACCEL/DECEL RATE	DECEL 1	Set to 0 to follow Master Profile
ACCEL/DECEL RATE	S-CURVE 1	Set to 0 to follow Master Profile
<u>Block</u>	<u>Parameter</u>	<u>Setting</u>
PROCESS CONTROL	MASTER ENCODER	Encoder counts of the Master pulse train

Continued on next page

Quadrature Pulse Follower Mode for Series 19H/20H SCR DC Drives with Armature or Analog Tach Feedback Continued

For all operating modes except Serial:

<u>Block</u>	<u>Parameter</u>	<u>Setting</u>
PROCESS CONTROL	FOLLOW I:O RATIO	Desired integer ratio between Master and Follower encoder counts

For Serial Operating Mode only:

<u>Block</u>	<u>Parameter</u>	<u>Setting</u>
PROCESS CONTROL	FOLLOW I:O RATIO	Master of encoder counts ratio
PROCESS CONTROL	FOLLOW I:O OUT	Follow of encoder counts ratio

The Follower drive is now ready to follow the velocity of the Master. Be sure to “Enable” both the Master and Follower controls to allow Master/Follower operation.

Master Speed and Direction Pulse Reference Mode for Series 19H and 20H SCR DC Drives with Armature or Analog Tach Feedback

Be sure an MPR/F expansion board is installed in the control. Check that the main control board terminal strip is wired for the controls' operating mode and the MPR/F expansion board output terminals are connected to the input terminals of an MPR/F expansion board installed in a Follower control.

Use the keypad to set these Level 1 parameters:

<u>Block</u>	<u>Parameter</u>	<u>Setting</u>
INPUT	OPERATING MODE	See Table 2-3
INPUT	COMMAND SELECT	As desired for operating mode selected
ACCEL/DECEL RATE	ACCEL 1	As desired
ACCEL/DECEL RATE	DECEL 1	As desired
ACCEL/DECEL RATE	S-CURVE 1	As desired

The Master control is now ready for operation. The Follower control must now be programmed for Speed and Direction Follower mode operation. Proceed to the appropriate section of this manual to program Speed and Direction Follower Mode for the appropriate control, ie. 15H, 18H, etc.

Speed and Direction Pulse Follower Mode for Series 19H and 20H SCR DC Drives with Armature or Tach Feedback

Be sure an MPR/F expansion board is installed in the Follower control and the input terminals of the expansion board are wired to the speed and direction pulse train output of the Master control or encoder located ahead of the Follower control in the process. Check that the main control board terminal strip is wired for the controls' operating mode.

Use the keypad to set these Level 1 parameters:

<u>Block</u>	<u>Parameter</u>	<u>Setting</u>
INPUT	OPERATING MODE	See Table 2-4
INPUT	COMMAND SELECT	EXB PULSE FOL
ACCEL/DECEL RATE	ACCEL 1	Set to follow Master Profile rate of the Master
ACCEL/DECEL RATE	DECEL 1	Set to follow Master Profile rate of the Master
ACCEL/DECEL RATE	S-CURVE 1	Set to follow Master Profile

Use the keypad to set these Level 2 parameters:

<u>Block</u>	<u>Parameter</u>	<u>Setting</u>
PROCESS CONTROL	MASTER ENCODER	Encoder counts of the Master pulse train

Continued on next page

Speed and Direction Pulse Follower Mode for Series 19H and 20H SCR DC Drives with Armature or Tach Feedback Continued

For all operating modes except Serial:

Block	Parameter	Setting
PROCESS CONTROL	FOLLOW I:O RATIO	Desired integer ratio between Master and Follower speed and direction encoder counts

For Serial Operating Mode Only:

Block	Parameter	Setting
PROCESS CONTROL	FOLLOW I:O RATIO	Master of encoder counts ratio
PROCESS CONTROL	FOLLOW I:O OUT	Follower of encoder counts ratio

The Follower drive is now ready to follow the velocity of the Master. Be sure to “Enable” both the Master and Follower controls to allow Master/Follower operation.

**Master Quadrature Pulse Reference Mode for
Series 18H and 22H Vector Drives, Series 19H and
20H SCR DC Drives with Encoder Feedback and
Series 23H AC Servo Controls**

This mode is not available or necessary for these controls. These controls feature a buffered encoder pulse train output that can be used as a Master input to an MPR/F expansion board installed in a Follower drive.

**Quadrature Pulse Follower Mode for
Series 18H and 22H Vector Drives,
Series 19H and 20H SCR DC Drives with Encoder
Feedback and Series 23H AC Servo Controls**

Be sure an MPR/F expansion board is installed in the Follower control and the input terminals of the expansion board are wired to the quadrature output of a Master control or encoder located ahead of the Follower control in the process. Check that the main control board terminal strip of the Follower drive is wired for the controls' operating mode.

Use the keypad to set these Level 1 parameters:

<u>Block</u>	<u>Parameter</u>	<u>Setting</u>
INPUT	OPERATING MODE	See Table 2-4
INPUT	COMMAND SELECT	EXB PULSE FOL Master Profile
ACCEL/DECEL RATE	ACCEL 1	Set to follow Master Profile
ACCEL/DECEL RATE	DECEL 1	Set to follow Master Profile
ACCEL/DECEL RATE	S-CURVE 1	Set to follow Master Profile
Velocity Following:		
Vector Control	Position Gain	Set to zero
Position Following:		
Vector Control	Position Gain	Increase from 0 until unwanted reversals occur, then reduce setting

Use the keypad to set these Level 2 parameters:

<u>Block</u>	<u>Parameter</u>	<u>Setting</u>
PROCESS CONTROL	MASTER ENCODER	Encoder counts of Master pulse train

Continued on next page

**Quadrature Pulse Follower Mode for
Series 18H and 22H Vector Drives,
Series 19H and 20H SCR DC Drives with Encoder
Feedback and Series 23H AC Servo Controls**

Continued

For all operating modes except Serial:

<u>Block</u>	<u>Parameter</u>	<u>Setting</u>
PROCESS CONTROL	FOLLOW I:O RATIO	Desired integer ratio between Master and Follower encoder counts

For Serial Operating Mode Only:

<u>Block</u>	<u>Parameter</u>	<u>Setting</u>
PROCESS CONTROL	FOLLOW I:O RATIO	Master of encoder counts ratio
PROCESS CONTROL	FOLLOW I:O OUT	Follower of encoder counts ratio

The Follower drive is now ready to follow the velocity or the position (with position gain added) of the Master. Be sure to "Enable" both the Master and Follower controls to allow Master/Follower operation.

Clear the Position Register - Follower Mode

The position register of the follower control can be cleared by opening the "Enable" input (disable the follower control). This is true for all operating modes that use the controls' terminal inputs. Also, in the process mode the position register can be cleared by commanding a Jog at the control terminal strip. Finally, the position register is cleared anytime the follower control is in the "Keypad" mode (no longer following).

**Master Speed and Direction Pulse Reference Mode for
Series 18H and 22H Vector Drives,
Series 19H and 20H SCR DC Drives with Encoder
Feedback and Series 23H AC Servo Controls**

This mode is not available or necessary for these controls. These controls feature a buffered encoder pulse train output that can be used as a Master input to an MPR/F expansion board installed in a Follower drive.

Speed and Direction Pulse Follower Mode
Series 18H and 22H Vector Drives,
Series 19H and 20H SCR DC Drives with Encoder
Feedback and Series 23H AC Servo Controls

Be sure an MPR/F expansion board is installed in the Follower control and the input terminals of the expansion board are wired to the encoder pulse train output of a Master control or encoder located ahead of the Follower control in the process. Check that the main control board terminal strip of the Follower drive is wired for the controls' operating mode.

Use the keypad to set these Level 1 parameters:

Block	Parameter	Setting
INPUT	OPERATING MODE	See Table 2-4
INPUT	COMMAND SELECT	EXB PULSE FOL
ACCEL/DECEL RATE	ACCEL 1	Set to 0 to follow Master Profile
ACCEL/DECEL RATE	DECEL 1	Set to 0 to follow Master Profile
ACCEL/DECEL RATE	S-CURVE 1	Set to 0 to follow Master Profile
Velocity Following:		
Vector Control	Position Gain	Set to zero
Position Following:		
Vector Control	Position Gain	Increase from 0 until unwanted reversals occur, then reduce setting

Use the keypad to set these Level 2 parameters:

Block	Parameter	Setting
PROCESS CONTROL	MASTER ENCODER	Encoder counts of Master

Continued on next page

Speed and Direction Pulse Follower Mode
Series 18H and 22H Vector Drives,
Series 19H and 20H SCR DC Drives with Encoder
Feedback and Series 23H AC Servo Controls

Continued

For all operating modes except Serial:

<u>Block</u>	<u>Parameter</u>	<u>Setting</u>
PROCESS CONTROL	FOLLOW I:O RATIO	Desired integer ratio between Master and Follower Speed and Direction encoder counts

For Serial Operating Mode Only:

<u>Block</u>	<u>Parameter</u>	<u>Setting</u>
PROCESS CONTROL	FOLLOW I:O RATIO	Master of encoder counts ratio
PROCESS CONTROL	FOLLOW I:O OUT	Follower of encoder counts ratio

The Follower drive is now ready to follow the velocity or the position (with position gain added) of the Master. Be sure to “Enable” both the Master and Follower controls to allow Master/Follower operation.

Clear the Position Register - Follower Mode

The position register of the follower control can be cleared by opening the “Enable” input (disable the follower control). This is true for all operating modes that use the controls’ terminal inputs. Also, in the process mode the position register can be cleared by commanding a Jog at the control terminal strip. Finally, the position register is cleared anytime the follower control is in the “Keypad” mode (no longer following).



Section 6

Troubleshooting

Overview

Before troubleshooting the Master - Follower system, verify that the controls operate the motors in the “Local” Mode. Table 6-1 lists the typical failure modes or symptoms exhibited by a system failure. For each symptom a list of possible causes and corrective actions to restore correct Master - Follower system operation are given.

Table 6-1 Troubleshooting Information

Symptom	Possible Cause	Corrective Action
Master control runs the master motor. In the quadrature pulse follower mode, the follower control does not follow the master motor speed.	1. Incorrect input parameter setting.	1. Verify the settings for the input parameters. Refer to Section 5 of this manual for programming information.
	2. Incorrect expansion board wiring.	2. Check encoder wiring to the expansion board and the retransmit wiring from the expansion board (if more than one follower is used).
	3. The follower control may not be enabled. Ensure the control is enabled at the Main Control Terminal Strip pins 8, 9, and 10 with ground at pin 17.	3. Verify these connections by observing the digital I/O screen. To observe this screen, use the keypad and select “Local” mode operation from the “Diagnostic Info” menu.
	4. Incorrect encoder signals into the expansion board.	4. Verify correct parameter setting. Refer to control manual for programming instructions.
	5. Incorrect DIP switch settings on the expansion board.	5. Verify DIP switch settings as detailed in “Hardware Setup” of this manual.
	6. Software does not support expansion board.	6. Verify EXB recognition in Diagnostics. If not recognized, contact Baldor District Office.

Table 6-1 Troubleshooting Information Continued

Symptom	Possible Cause	Corrective Action
Motor following Master Control is running at a fixed speed, an erratic speed or reverses direction intermittently.	1. Position Gain is too high.	1. Reduce the value of Position Gain parameter or set to zero to disable the position control loop. Disabling the position control loop will put the follower into a velocity follower mode.
	2. Noise may be present on the input to the expansion board.	2. Verify shields of the twisted pairs are connected to digital ground, terminal 55 on the MPR/F board.
	3. Control may be programmed incorrectly.	3. Verify programming parameters are correct. Refer to Section 6 of this manual for software setup information.
Follower control operates the motor in the wrong direction.	1. Encoder phase wiring reversed.	1. Swap the input A and \bar{A} channel wires at the MPR/F board inputs. (Pins 51 and 52).
If in Standard Run 3-Wire operating mode for a Series 15H or 21H Inverter or; 19H or 20H SCR DC control with armature feedback, the follower does not run.	1. Encoder channel B leading channel A with the 3-Wire unipolar input command.	1. Swap encoder inputs A and \bar{A} into the MPR/F board. (Pins 51 and 52).
If in Bipolar. Serial or Process Operating mode for a Series 18H, 22H or 20H with encoder feedback, the follower does not run or runs in one direction only.	1. Directional enables or ground not correctly activated.	1. Check to make sure the control is enabled at the Main Control Terminal Strip pins 8, 9, and 10 with ground at pin 17.

BALDOR[®]
MOTORS AND DRIVES

BALDOR ELECTRIC COMPANY

P.O. Box 2400

Fort Smith, AR 72902-2400

(479) 646-4711

Fax (479) 648-5792

© Baldor Electric Company
MN1312

Printed in USA
2/03 C&J1500